

Blowout Preventers



LEADING
THROUGH
INNOVATION

www.womgroup.com



WORLDWIDE OILFIELD MACHINE

TABLE OF
CONTENTS



WOM's BOP Stack	4
WU BOP Major Features	6
WU BOP Specifications	7
WU BOP Dimensional Data (Single)	8
WU BOP Dimensional Data (Double)	9
WU BOP Components	10
WU BOP Parts and Large Bore Shear Bonnet Parts	11
Rams for WU BOP	12
WU Pipe Ram	12
WU Variable Bore Ram.....	12
WU Shearing Blind Ram.....	12
Hydraulic Control System	13
Super Power Tandem Booster	14-15
WU BOP Care & Maintenance	16
Cold Weather Operation	17
WGK Annular BOP (Screw and Latch Type)	18
WGK Annular Major Components	19
WGK Hydraulic Control System	20
WGK Annular Type BOP	21
WGK Engineering & Dimensional Data (Screw Type)	22
WGK Engineering & Dimensional Data (Latch)	23
WGK Packing Unit	24
WGK BOP Care & Maintenance (Screw and Latch Type)	25
29 1/2" 500 PSI MSP Diverter BOP (Latch Type)	26

WOM'S BOP Stack

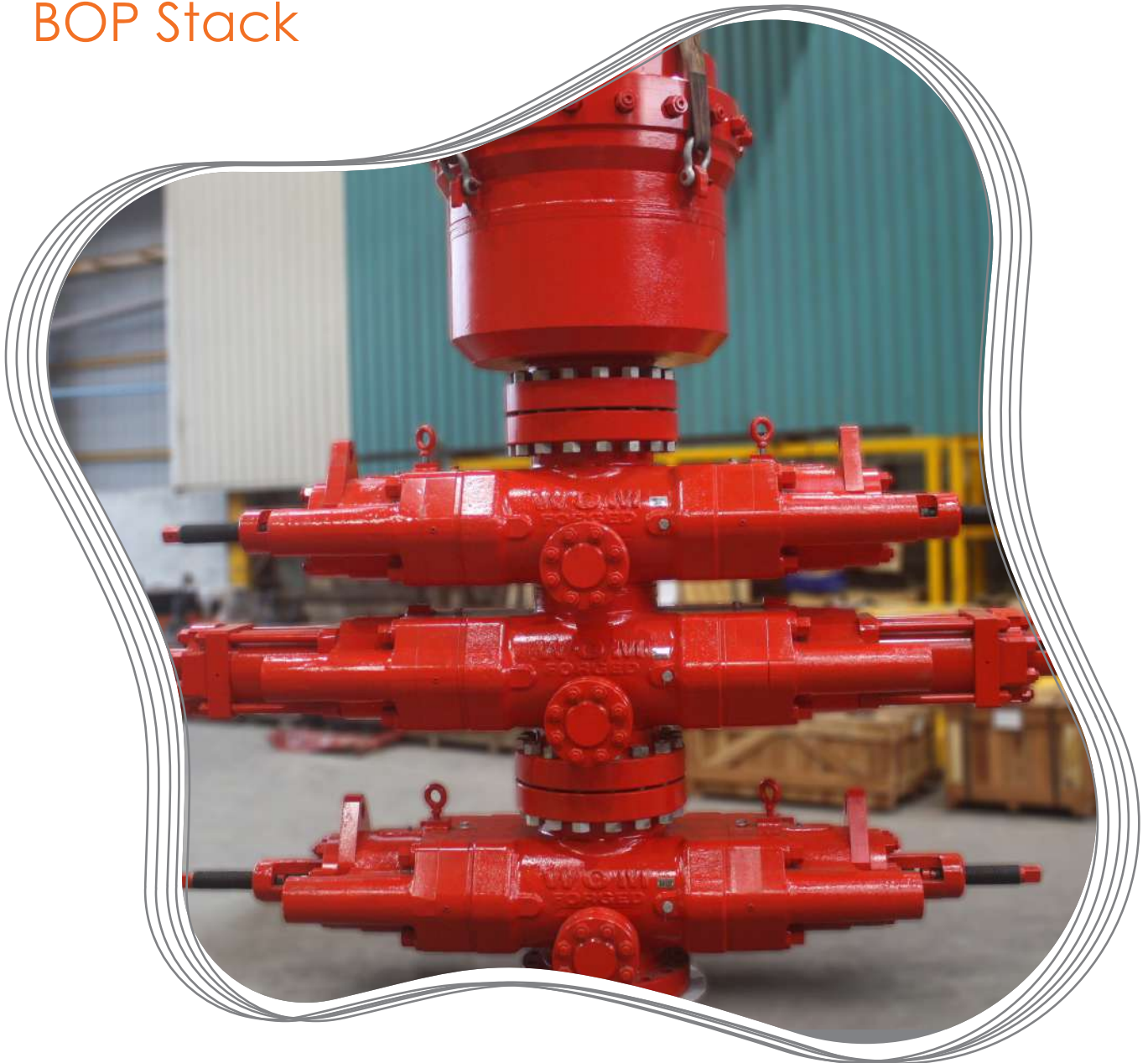

*Typical WOM WGK Annular and
WU Ram Type BOP Assembly*

WOM is certified to ISO 9001. Designed to NACE MR-01-75 Materials Standards for resistance to sulfide stress cracking are standard.



WOM products are manufactured by the highest applicable standards. Computer controlled machine tools are used for dimensional accuracy, precision machining and consistent high quality. Each product is inspected, assembled and tested prior to shipment. This attention to detail ensures product quality and on time delivery.

All buyouts like fittings, elastomers such as "O"rings, stem packing are supplied by WOM-Houston, headquarters. The assembly and testing of the valves is performed in a controlled area free from contamination. The assembly and testing conforms to written assembly and testing procedures, which are strictly enforced in order to maintain the high quality of our products. Material specifications, including heat treatment, mill tests, equipment tests are maintained in our manufacturing files which when requested can be supplied to the customer.

“Attention to detail ensures product quality and on-time delivery.”

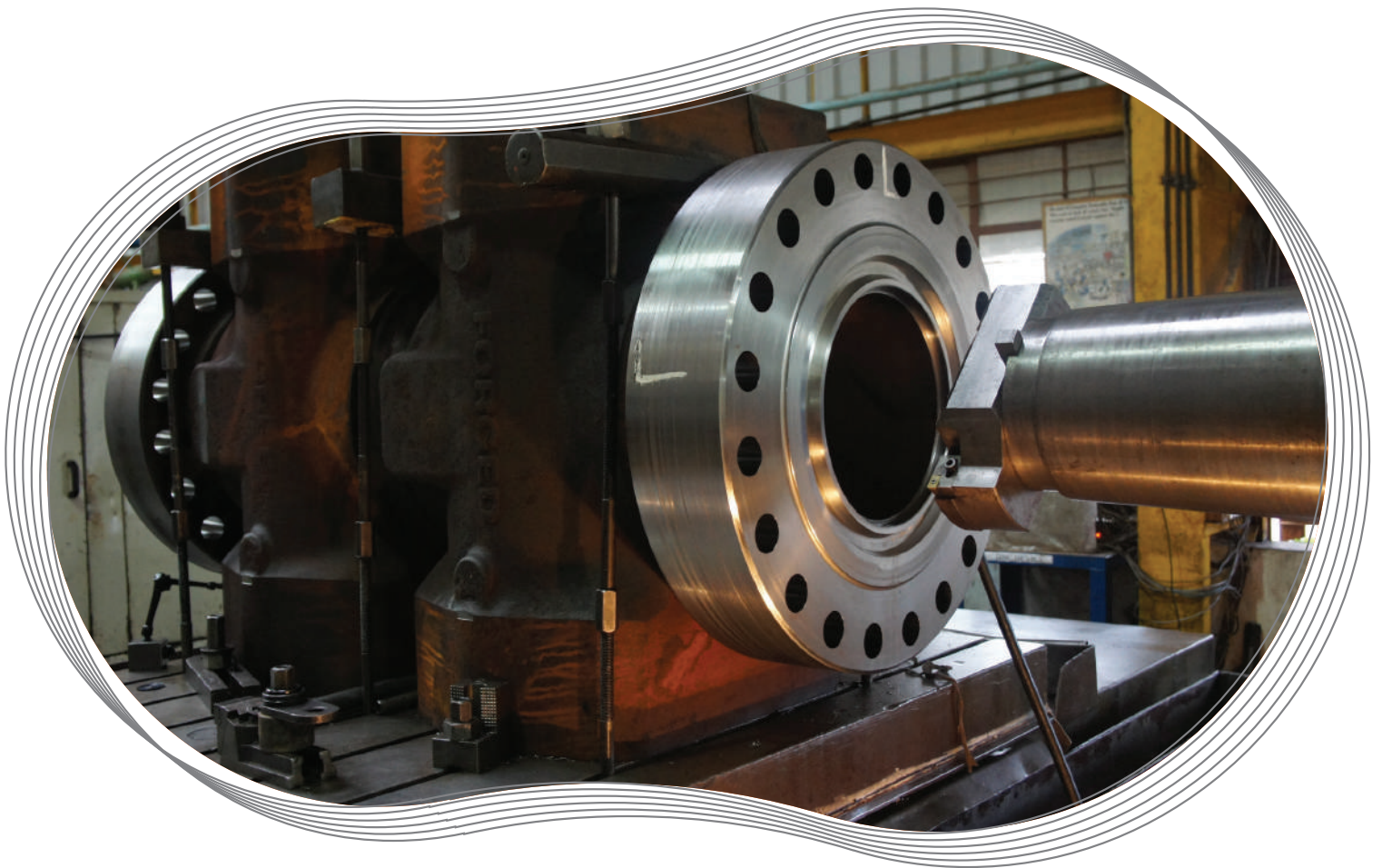

WU BOP

Major Features

The "U" BOP is the most widely used BOP type in the world today. Its simple, compact design makes it well suited for operations offshore and onshore. WOM's ram type "WU" BOP operating system is designed to provide a fast and reliable closure around pipe or casing in the well bore. The sealing is energized by the pressure and is maintained even with loss of closing pressure.

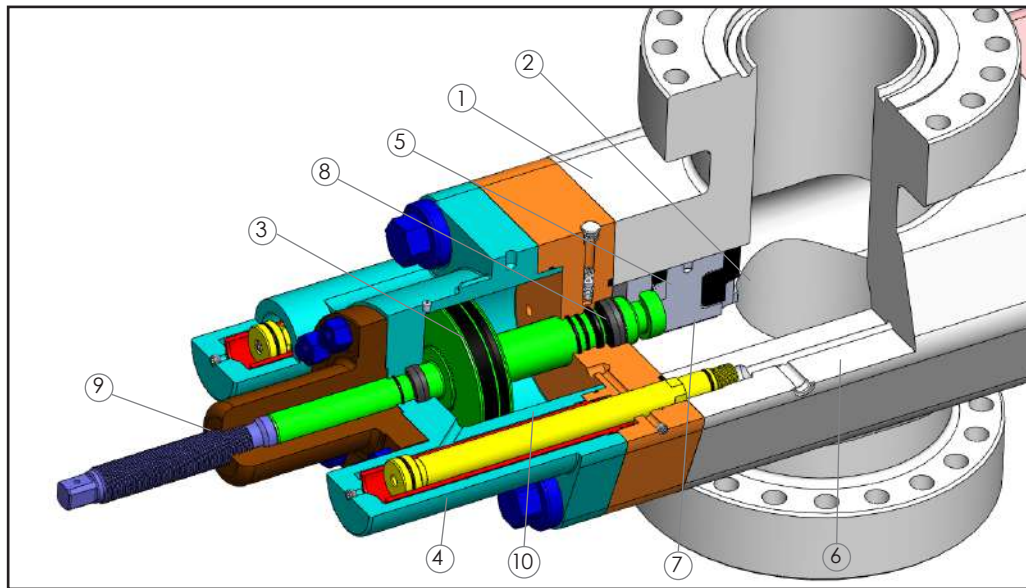

View of Major Components

1. Major components are forged or cast for uniform strength, impact resistance and freedom from defects.
2. Ram packing is generous and self-feeding. It cannot be dislodged by fluid flow.
3. Operating pressure is moderate, due to large piston area.
4. Bonnets are opened and closed by hydraulic pressure.
5. Ram change is quick and easy.
6. All working parts and control fluid passages are enclosed.
7. Well bore pressure aids in holding rams closed.
8. Two seals and a vent hole prevent well pressure from bleeding into operating cylinder.
9. Rams can be locked in closed position by optional hydraulic ram locks. Release of locks is positive when opening of rams is desired.
10. All operating parts, as well as rams and seals, can be replaced on location, thus providing a completely reconditioned preventer.
11. We offer triple-seal protection from the well pressure.

WU BOP Specifications

The capital letters in the following designations refer to the WU BOP dimensional views and dimensions tables on pages 8 and 9.

A-1 Length: Bonnets closed, locking screws locked	E-2 Centerline of side outlet to bottom hub face
A-2 Length: Bonnets opened, locking screws unlocked	F-1 Top of upper ram to top flange face
A-3 Length: Bonnets closed with wedgelocks	F-2 Top of upper ram to top hub face
A-4 Length: Bonnets opened with wedgelocks	G Height of Ram
B-1 Height: Flanged	H-1 Centerline of side outlet between rams to bottom hub face
B-2 Height: Clump hubs	H-2 Centerline of side outlet between rams to bottom hub face
C Width: No side outlets	J Top of lower ram to bottom of upper ram face
E-1 Centerline of side outlet to bottom flange face	

The following applications apply to typical WU type BOPs. Side outlets to 4-1/16" can be provided beneath each set of rams on either or both sides of WU BOPs. Side outlets can be studded, open-faced flange, or clamp hub.

Flanges conform to API standards 6A and/or 16A. Hubs conform to API 16A or applicable standards. Type 6BX flanges are standard for 10,000 and 15,000 psi working pressures and for 5,000 psi for 13 -5/8" and larger bore BOP's.

Hydraulic control connections for operation of rams and bonnets are 1" NPT. There are (2) connections for each set of rams. Wedgelock connections are 1/2" NPT.

The dimensions table (page 7 and 8) does not include spacers between rams for double ram models. WU BOPs with spacers to clear tool joints are available upon request.

Large bore shearing bonnets are available for shearing high-strength pipe. All WOM WU BOPs are suitable for H2S service as standard.

The WU BOP can be outfitted with blind rams, shearing/blind rams, pipe, casing, or tubing rams, or variable-bore rams.



WU BOP Dimensional Data (Single)

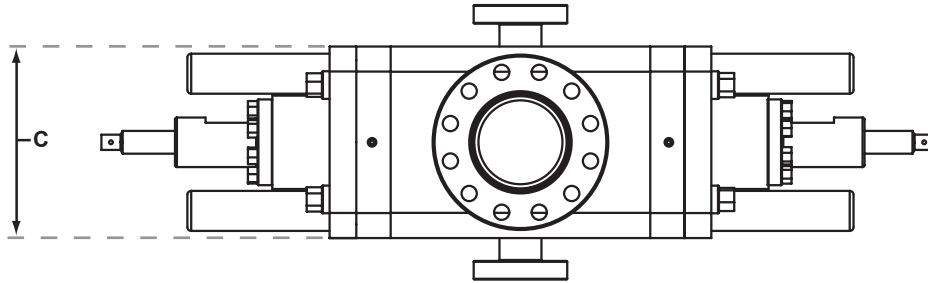

Top View of Single WU BOP

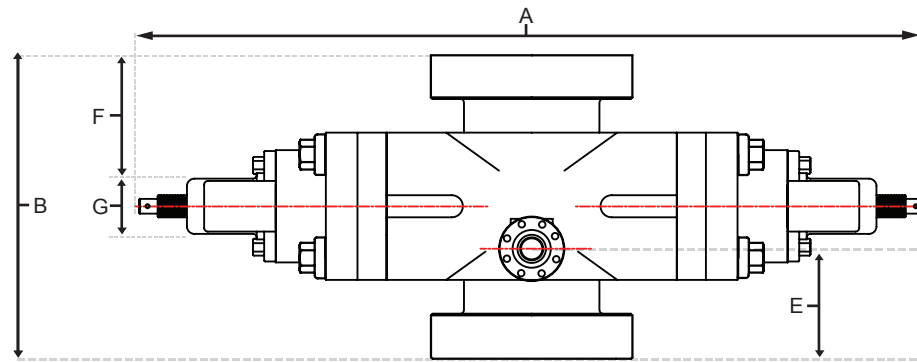

Side View of Single WU BOP

Single Open-Faced Flange or Clamp Hub WU BOP Dimensions

Size	Pressure Rating (psi)	Vertical Bore	A-1	A-2	A-3	A-4	B-1	B-2	C	E-1	E-2	F-1	F-2	G	Approx. Weight (lbs)
7-1/16"	3,000	7-1/16	74.00	109.50	-	-	24.06	-	20.25	8.75	-	7.84	-	5.50	2,600
7-1/16"	5,000	7-1/16	74.00	109.50	-	-	30.25	27.00	25.25	10.41	9.25	9.63	8.47	5.50	2,800
7-1/16"	10,000	7-1/16	74.00	109.50	-	-	30.25	27.00	20.63	11.06	9.38	12.03	10.34	5.50	3,550
7-1/16"	15,000	7-1/16	74.00	109.50	-	-	31.81	-	20.63	11.69	-	12.66	-	5.50	3,800
11"	3,000	11	96.25	146.88	-	-	29.06	-	25.13	9.81	-	10.53	-	6.75	5,300
11"	5,000	11	96.25	146.88	110.13	150.19	34.31	29.31	25.13	12.44	9.94	13.17	10.66	6.75	5,600
11"	10,000	11	96.25	146.88	110.13	150.19	35.69	32.19	25.75	13.13	11.38	13.84	12.09	6.75	6,400
11"	15,000	11	124.00	175.31	124.50	167.13	44.81	33.88	32.00	16.69	11.22	17.78	12.31	9.25	10,300
13-5/8"	3,000	13-5/8	112.13	171.50	122.69	166.06	31.31	-	29.25	10.31	-	11.53	-	7.50	7,200
13-5/8"	5,000	13-5/8	112.13	171.50	122.69	166.06	33.81	31.94	29.25	11.56	10.63	12.78	11.84	7.50	7,700
13-5/8"	10,000	13-5/8	114.13	172.75	124.69	167.31	41.69	32.81	30.25	15.13	10.69	17.09	12.66	7.50	10,300
13-5/8"	15,000	13-5/8	139.00	214.38	152.25	205.50	53.69	42.00	39.50	21.38	15.50	22.84	17.00	8.00	23,700
18-3/4"	10,000	18-3/4	156.38	242.13	166.50	226.63	56.00	43.23	42.50	20.50	13.88	22.00	15.34	12.00	29,000
18-3/4"	15,000	18-3/4	160.0	246.0	170.0	230.0	68.38	57.31	45.5	24.25	18.5	26.93	21.12	11.50	32,000
20-3/4"	3,000	20-3/4	143.69	226.81	163.94	223.88	40.56	33.31	39.52	14.31	10.69	16.28	12.66	8.00	13,650
21-1/4"	2,000	21-1/4	143.69	226.81	163.94	223.88	37.19	33.31	39.52	12.63	10.69	14.59	12.66	8.00	13,350
26-3/4"	3,000	26-3/4	169.63	275.38	-	-	48.31	-	46.25	17.44	-	19.91	-	8.00	24,000



WU BOP Dimensional Data (Double)

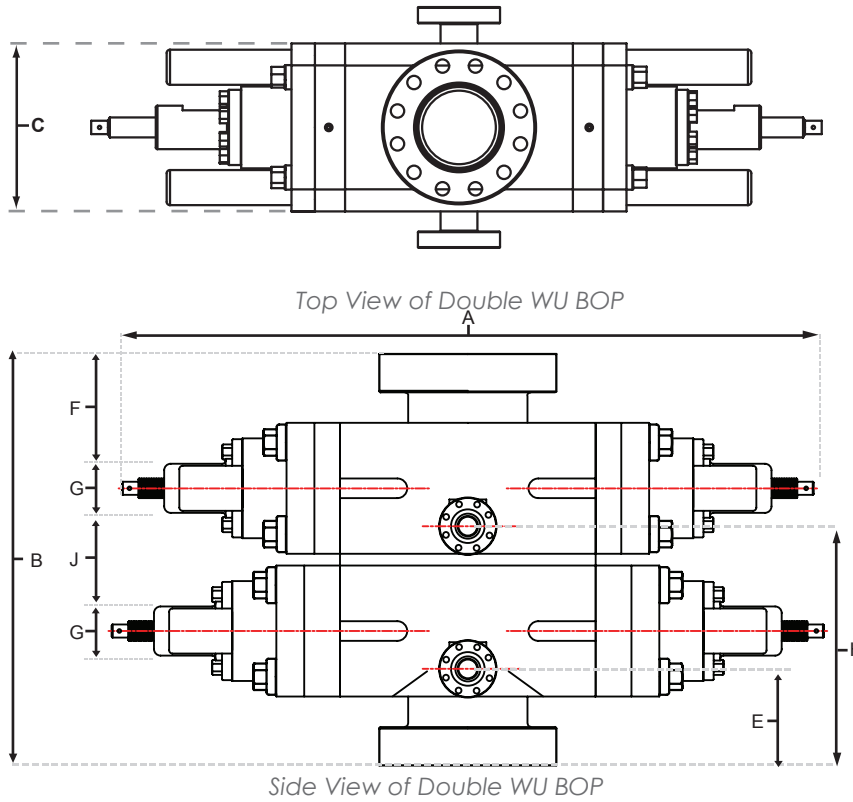

Double Open-Faced Flange or Clamp Hub WU BOP Dimensions

Size	Pressure Rating (psi)	Vertical Bore	A-1	A-2	A-3	A-4	B-1 (Flange)	B-2 (Clamp)	C	E-1	E-2	F-1	F-2	G	H-1 (Flange)	H-2 (Clamp)	J (Between)	Approx. Weight (lbs)
7-1/16"	3,000	7-1/16"	74	109.5	-	-	41	-	20.25	8.75	-	7.84	-	5.5	25.69	-	11.44	5,000
7-1/16"	5,000	7-1/16"	74	109.5	-	-	44.19	41.88	20.25	10.4	9.25	9.63	8.47	5.5	27.09	25.94	11.19	5,200
7-1/16"	10,000	7-1/16"	74	109.5	-	-	48.63	45.25	20.63	11.06	9.38	12.03	10.34	5.5	29.13	27.44	12.56	6,400
7-1/16"	15,000	7-1/16"	74	109.5	-	-	49.88	-	20.63	11.69	-	12.66	-	5.5	29.75	-	12.56	6,750
11"	3,000	11"	96.25	146.88	-	-	49.25	-	25.13	9.81	-	10.53	-	6.75	30	-	13.44	9,900
11"	5,000	11"	96.25	146.88	110.13	150.19	54.5	49.5	25.13	12.44	9.94	13.17	10.66	6.75	32.63	30.13	13.44	10,200
11"	10,000	11"	96.25	146.88	110.13	150.19	55.88	52.38	25.75	13.13	11.38	13.84	12.09	6.75	33.31	31.56	13.44	11,300
11"	15,000	11"	124	175.31	124.5	167.13	69.75	58.81	32	16.69	11.22	17.78	12.31	9.25	41.63	36.16	15.69	18,400
13-5/8"	3,000	13-5/8"	112.13	171.5	122.69	166.06	53.38	-	29.25	10.31	-	11.53	-	7.5	32.38	-	14.56	14,300
13-5/8"	5,000	13-5/8"	112.13	171.5	122.69	166.06	55.88	54	29.25	11.56	10.63	12.78	11.84	7.5	33.63	32.69	14.56	14,800
13-5/8"	10,000	13-5/8"	114.13	172.75	124.69	167.31	66.63	57.75	30.25	15.13	10.69	17.09	12.66	7.5	40.06	35.63	17.44	18,400
13-5/8"	15,000	13-5/8"	139	214.38	152.25	205.5	81.75	70.13	39.5	21.38	15.5	22.84	17	8	49.44	43.56	20.06	43,250
18-3/4"	10,000	18-3/4"	156.38	242.13	166.5	226.63	87.13	74	42.5	20.5	13.88	22	15.34	12	51.5	44.88	19.13	57,000
18-3/4"	15,000	18-3/4"	160.00	246.00	170.0	230.00	99.50	88.5	45.5	24.25	18.50	26.93	21.12	11.5	58.38	52.88	23.00	62,000
20-3/4"	3,000	20-3/4"	143.69	226.81	163.94	223.88	66.13	58.88	39.52	14.31	10.69	16.28	12.66	8	39.88	36.25	17.56	25,550
21-1/4"	2,000	21-1/4"	143.69	226.81	163.94	223.88	62.75	58.88	39.52	12.63	10.69	14.59	12.66	8	38.19	36.25	17.56	25,150
26-3/4"	3,000	26-3/4"	169.63	275.38	-	-	78.88	-	46.25	17.44	-	19.91	-	8	48	-	22.56	44,200



WU BOP Components

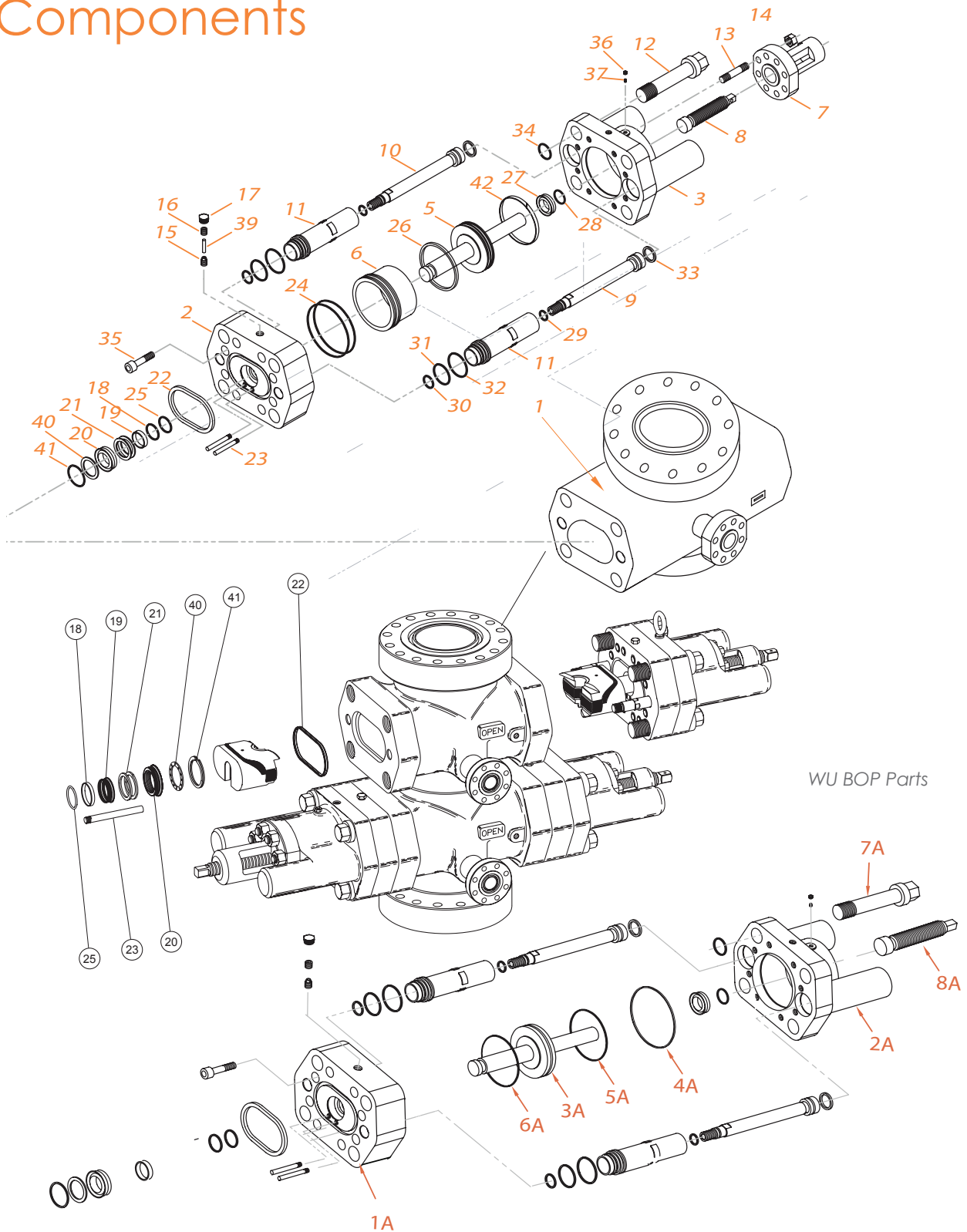

WU BOP Parts

WU BOP Parts	
Item Number	Description
1	Body
2	Intermediate Flange
3	Bonnet
4	Ram Assembly (not shown)
5	Piston, Operating
6	Cylinder, Operating
7	Housing, Locking Screw
8	Locking Screw
9	Piston, Ram Change/Open
10	Piston, Ram Change/Close
11	Cylinder, Ram Change
12	Bolt, Bonnet
13	Stud, Locking Screw Housing
14	Nut, Locking Screw Housing
15	Check Valve, Plastic Packing
16	Screw, Plastic Packing
17	Pipe Plug, Plastic Packing
18	Ring, Plastic Packing
19	Ring, Plastic Energizing
20	Seal Ring, Connecting Rod
21	Ring Back-Up
22	Seal, Bonnet
23	Pin, Ram Guide
24	O-Ring, Operating Cylinder
25	O-ring, Operating Piston Rod to Int. Flg
26	Lip Seal, Operating Piston
27	Seal Ring, Tail Rod
28	O-Ring Wiping
29	O-Ring, Ram Change Piston to Body
30	O-Ring, Ram Change Piston Rod to Int. Flg.
31	O-Ring, Ram Change Cylinder to Int. Flg
32	O-Ring, Ram Change Cylinder to Bonnet
33	O-Ring, Ram Change Piston
34	O-Ring, Bonnet Bolt Retainer
35	Cap Screw, Int. Flange to Bonnet
36	Gland Bleeder
37	Plug Bleeder
38	*Lifting Eye (not shown)
39	Plastic Packing
40	Washer
41	Ring, Retainer
42	Wear Ring, Operating Piston

Large Bore Shear Bonnet Parts	
1A	Intermediate Flange
2A	Bonnet/Shear
3A	Operating Piston/LB
4A	O-Ring, Int. Flg to Bonnet Lip
5A	Lip Seal, Operating Piston/LB
6A	Wear Ring, Operating Piston/LB
7A	Bonnet Bolt Shear
8A	Lockscrew Shear

Large bore shear bonnets provide a larger operating piston to increase shearing force.

Part Numbers for WU BOP

*38 - Must be ordered seperately

All dimensions are in inches unless otherwise noted.



Rams for WU BOP's

WU BOP Pipe Rams

WU BOP pipe rams are available to fit a wide variety of tubing, drill pipe, drill collar, and casing sizes.

All rams are suitable for H₂S service per NACE specifications. WU BOP ram packers are self-feeding with a large reserve of elastomer to ensure a long-lasting seal under all conditions. Ram packers lock into place and cannot be dislodged by well flow.

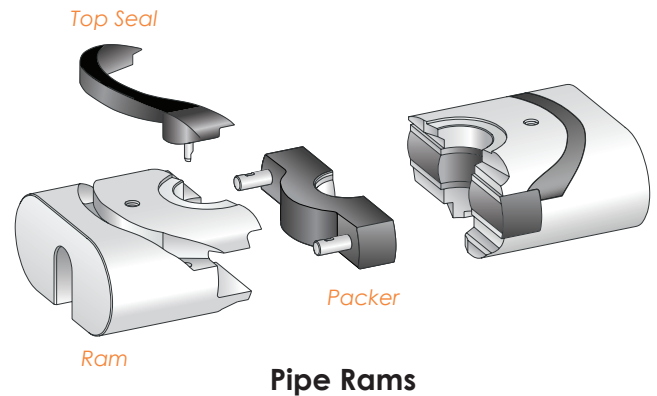

WU BOP Variable Bore Rams

WU BOP variable bore rams can be used to seal on a range of pipe. WOM's WU BOP variable bore ram packers contain steel reinforcing inserts similar to those in the annular BOP packer. The inserts rotate inward when the rams are closed so the steel provides support for the rubber which seals against the pipe.

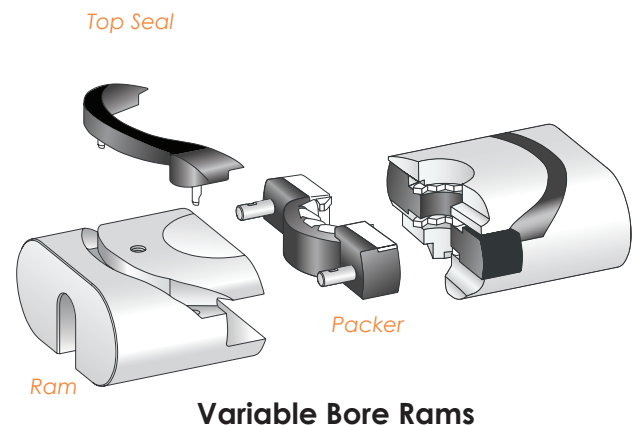

WU BOP Shearing Blind Rams

Shearing blind rams (SBR) can be used as blindrams during normal operations, they are specifically designed to shear the pipe in the hole then bend the lower section of the sheared pipe to allow the rams to close and seal.

One set of WU BOP variable bore rams can be used to seal on a range of pipe. WOM's WU BOP variable bore ram packers contain steel reinforcing inserts similar to those in the annular BOP packer. The inserts rotate inward when the rams are closed so the steel provides support for the rubber which seals against the pipe. The large area of the blade face seal reduces pressure on the rubber and increases service life. WOM SBRs can cut pipe numerous times without damage to the cutting edge.

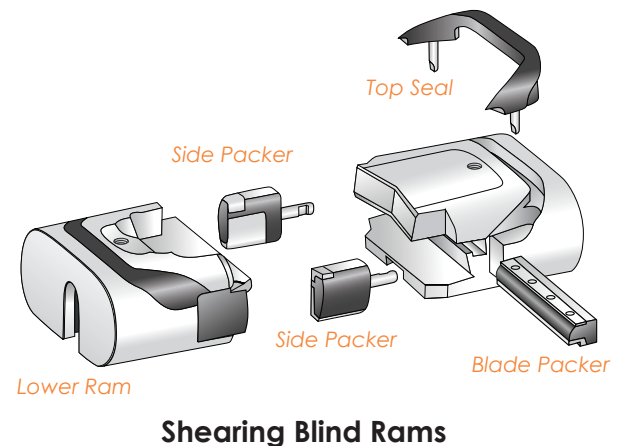

Hydraulic Control System

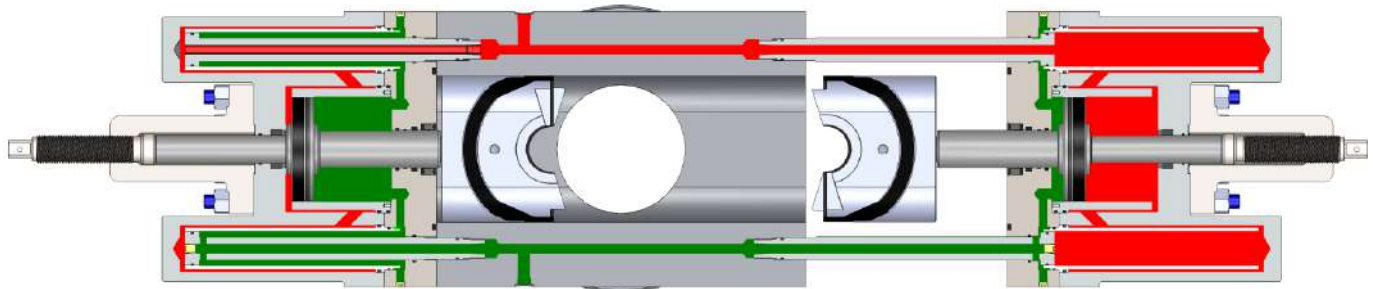

View of Hydraulic Control System

Ram Close Circuit in Red
Ram Open Circuit in Green

Hydraulic Circuits

The ram close hydraulic circuit is shown in red on the above caption. The ram closing pressure also serves to open the bonnets for ram change. When the bonnet bolts are unscrewed and closing pressure is applied, pressure pushes the ram inward and at the same time moves the bonnet away from the preventer body. Even though the ram moves inward, the bonnet stroke is sufficient to bring the ram into the clear for handling. An eyebolt is furnished on each end of the Preventer body which can be screwed into the top of each ram for lifting.

The ram open hydraulic circuit is shown in green on the above caption. Ram opening pressure also serves to close the bonnets. Hydraulic control pressure draws the bonnets tightly against the preventer body; bolts serve only to hold bonnets closed. An important feature of the Type "WU" hydraulic system is that the rams are pulled back close to the bonnets before the bonnets begin moving toward the Preventer body. Because of this, rams never interfere with pipe in the hole or otherwise obstruct the vertical bore. Rams may be changed, in an emergency, when the well is blowing, thereby increasing the security provided by the preventers.

Pressure Required

The rated continuous working pressure for the Type "WU" BOP operating system is 1,500 psi. Pressures of 300 to 500 psi normally provide satisfactory operation. Pressures in excess of 1,500 psi may be required in 10,000 and 15,000 psi preventers to close the rams against high well pressures. In emergencies, pressures up to 4,500 psi can be applied to the hydraulic controls. For optimum seal life, the applied hydraulic pressure should be limited to 1,500 psi, especially when it is customary to hold "ram open" pressure on preventers continuously. When a 3,000 psi accumulator is used to store maximum energy for preventer operation, a pressure regulator should be used to control pressure applied to the preventer.

Operating Fluids

Light hydraulic oil is the recommended operating fluid for Type "WU" preventers. Any type is satisfactory except fuel oil, which causes rubber seals to swell and deteriorate. The use of water as an operating medium is satisfactory provided soluble oil is added to prevent corrosion and antifreeze is added when necessary. Should an emergency require the use of drilling mud pressure to operate a Preventer, the Preventer should be torn down, thoroughly cleaned and all seals carefully checked for excessive wear as soon as practical thereafter.



Super Power (SP) Tandem Booster*

WOM's new Super Power (SP)-Tandem Boosters* are designed to enhance the shearing force of Ram-type BOPs. WOM's SP –Tandem Boosters offer more advantages and benefits over those of traditional shear boosters.

- May be utilized on any size of ram-type BOP such as but not limited to 7-1/16", 11", 13-5/8", 18 3/4" and 21 1/4".
- Offers ability to shear larger and heavier sizes of drill pipe required for deep drilling, where extra heavy wall-thickness is required for hydrocarbon producing wells or extreme sour environments.
- SP-Tandem Boosters with large bore bonnets have a rigid power of approximately one million pound force, capable of shearing drill pipe at any extreme well condition and harsh environment.
 - SP-Boosters provide twice the shearing force than traditional tandem boosters.
- SP-Tandem Boosters use of internal hydraulic flow path for hydraulic operations, eliminates external piping and exposure to damage during handling, storage, and shipping.
- Quick and easy field replacement of standard seals.
 - The SP-Tandem Booster uses the same seals as the large bore piston and shaft seals.
- Rigid and robust design. Each part is engineered in-house to meet and/or exceed national petroleum industry code and standards.
- Requires only three main components: Housing, Piston and End Plate; making assembly and disassembly quicker with low maintenance.
- Eliminates the need for spacers, connectors, and other parts used in traditional tandem

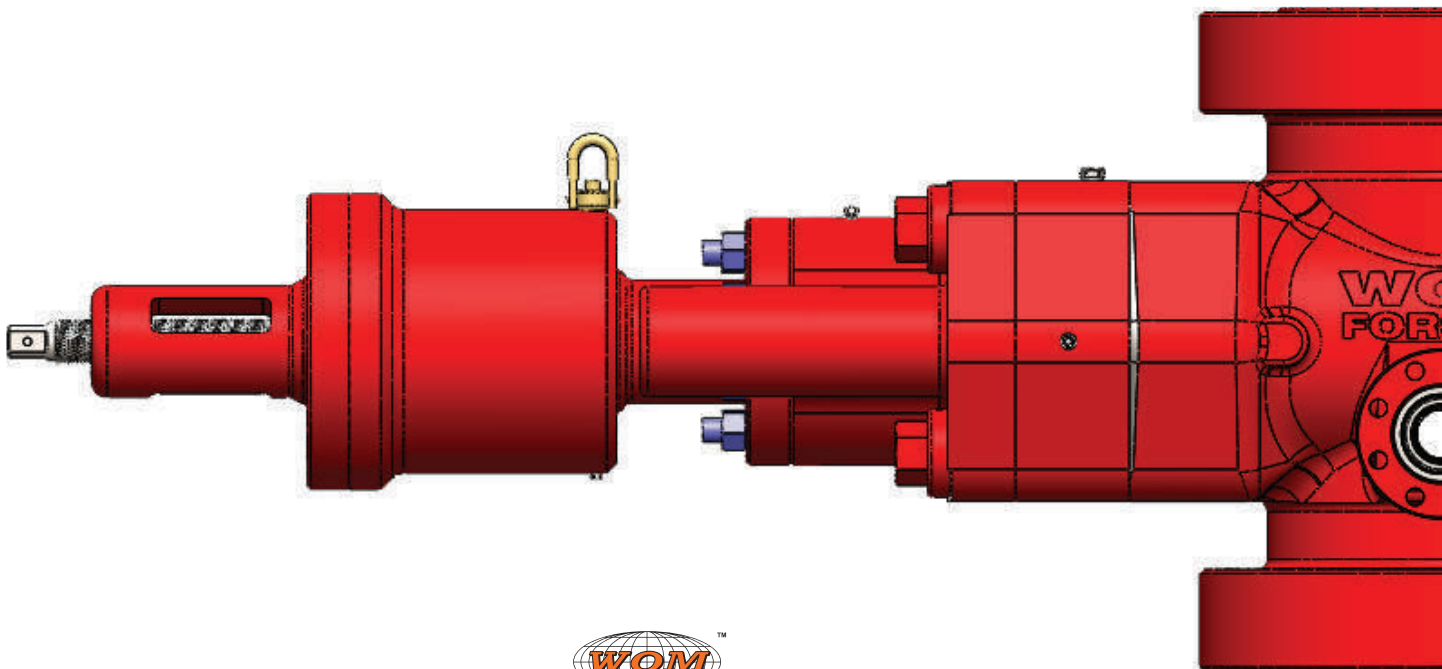

- boosters.
- Weighs less than traditional boosters.
- Existing WU BOPs and other OEM BOPs may be retrofitted with SP-Tandem boosters to provide extra shearing force.
 - External hydraulic lines may be required for retrofit applications.
- May be utilized in smaller size ram-type BOPs, offering a reduction in size, weight and overall cost.
- WOM has successfully completed shear tests on 13 5/8" 10,000-psi blowout preventer utilizing SP-Tandem Shear Booster for the following drill pipes, witnessed by WOM's certified quality assurance personnel as per API-16A guidelines.
 - Drill Pipe OD 5", Grade S-135, PPF 25.6, closing pressure 2300-psi
 - Drill Pipe OD 5 1/2", Grade S-135, PPF 24.7, closing pressure 2200-psi
 - Drill Pipe OD 6 5/8", Grade S-135, PPF 25.2, closing pressure 1500-psi
 - Drill Pipe OD 6 5/8", Grade S-135, PPF 27.6, closing pressure 2,400-psi
- Above test criteria and governing rules meet the requirements of hydraulic closing pressure for drill pipe shear as per API-53 which is 90% below the rated hydraulic maximum pressure.

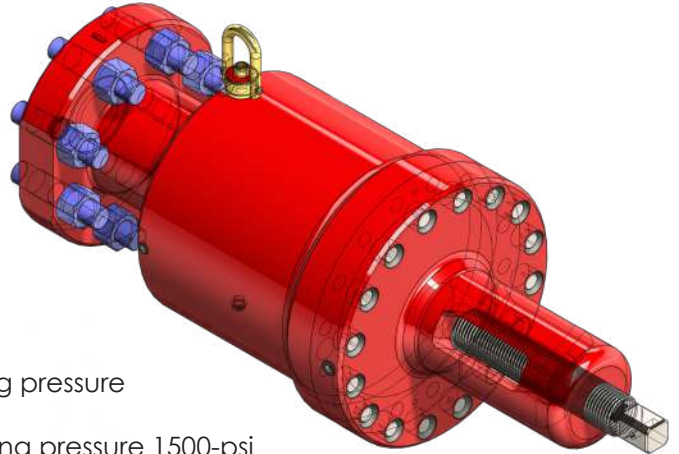

(Test charts and test data is available on request)

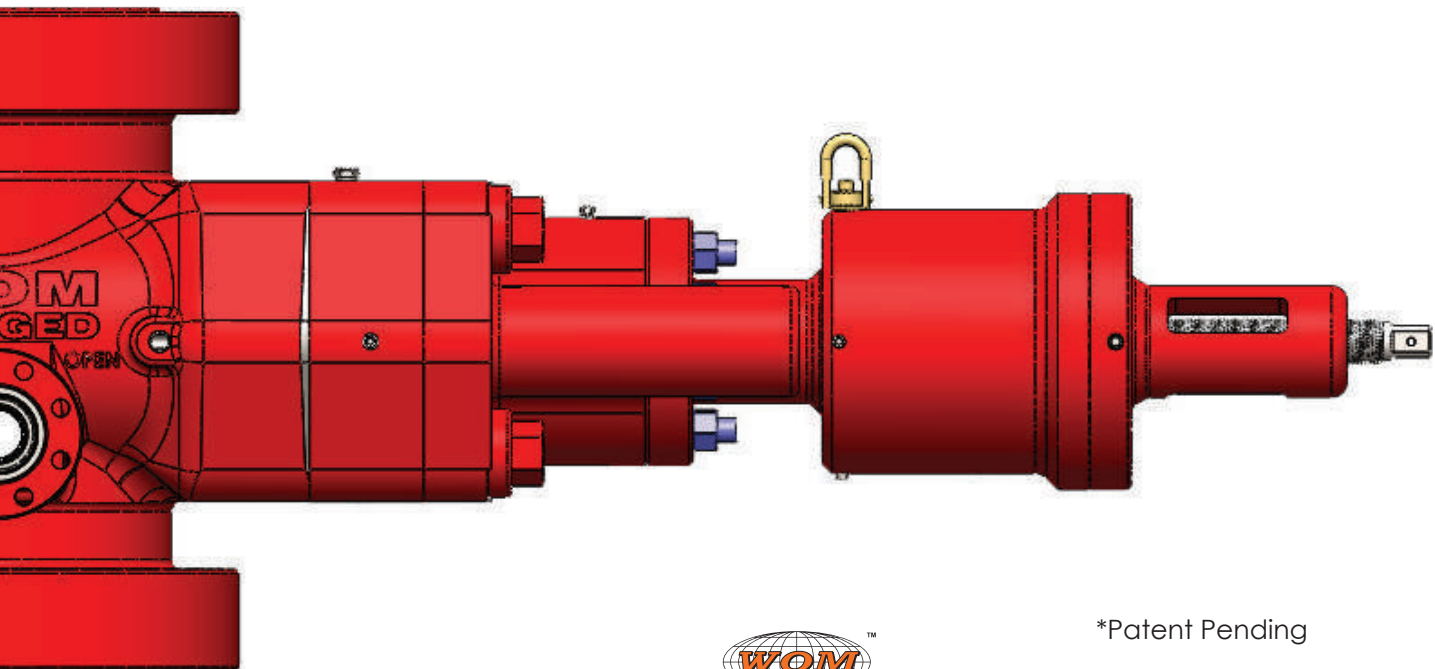

*Patent Pending

WU BOP

Care & Maintenance

Daily or Trip Care: All blowout Preventers should be operated daily. Many owners require that they be operated at the beginning of each tour. Blind rams should be operated every time pipe is out of the hole. Pipe rams should not be closed except when pipe is in the preventer, to avoid extruding the packer. If operation of the rams requires more than 500 psi control pressure when there is not pressure in the well bore, the cause should be determined and remedial measures taken.

Care Between Wells: Whenever a preventer is removed from a drilling hookup, it should be carefully cleaned, and the rams should be removed, cleaned, inspected, and lubricated. Also, the ram bore should be cleaned, inspected and lubricated. Any burrs or galled spots should be smoothed. Rams may be stored in the preventer or separately. The operating system should be thoroughly flushed to remove sediment or foreign material. Type "WU" Preventers should be transported with rams closed and locking screws run in to avoid accidental bending of locking screws.

Periodic Overhaul: Annually, or more often depending on the type of service, a preventer should be completely disassembled and all parts cleaned, inspected and reconditioned or replaced. All rubber seals should be replaced except ram packings which should be replaced according to condition. Any metal parts which show damage, such as scored pistons or cylinders, should be replaced or repaired.

Preventer parts in some cases can be repaired; however, this should be done only at WOM repair shops or under supervision of WOM personnel. After the preventer is rebuilt, the body should be tested to maximum rated working pressure and the operating system to 5,000 psi. The Type WU Blowout Preventer has been designed especially for ease of field servicing and reconditioning. Ram change pistons and cylinders, and operating pistons and cylinders can be quickly replaced on location, providing a completely rebuilt bonnet assembly.

Lubricants: Ram Lubricant: Any water resistant grease or heavy oil can be used as a ram and ram bore lubricant. Thread Lubricant: Metallic Zinc Base Grease should be used.

Testing: At regular intervals, weekly if possible, the complete drilling hookup and choke manifold should be tested for pressure holding ability and correct operation. The blowout preventer operating unit and all control piping should also be pressure tested and inspected. Pipe rams should not be closed except when pipe is in the preventer, to avoid extruding the packing.

Storage: When a preventer is put in storage, the rams should be removed and the preventer thoroughly cleaned, all moving parts greased, and all machined surfaces oiled and greased, particularly the ram bores and the flange ring grooves. Preferably, the preventer should be provided with flange protectors. Preventers in storage should have the operating system full of lightweight oil. Packed rams should not be stored out of doors.

Spare Parts: It is recommended that spare pipe rams plus replacement packers and top seals for all sizes of rams being used be kept at the rig. There may be other spare parts that are recommended to support a year of operation, which depend on environmental conditions where the BOP is installed. Please contact WOM for a specific list of recommended spares.



Cold Weather Operation

The operation of the Type WU Blowout preventer in sub-zero temperatures requires special precautions not normally necessary in the more temperate climates such as that of the Gulf Coast area. Some of these precautions are:

1. The preventer should be kept as warm as possible as the rams are susceptible to freezing in place since water-based drilling fluids freeze quickly and solidly when they come to rest at such temperatures.
2. Lubricants should be selected on their low temperature properties since some lubricants congeal at sub-zero temperatures and prevent the operations which they were intended to facilitate.
3. Avoid impact loads on rubber parts as they become very brittle and may shatter.
4. Use metallic hose in lieu of rubber hose due to rubber embrittlement.
5. Light hydraulic oil should be used in the Type WU hydraulic system since some medium-weight oils become semi-solid at temperatures in the neighborhood of fifty degrees below zero.
6. Keep the equipment clean and free of water-based drilling fluids where at all possible.
7. Operate the equipment as frequently as possible.



WGK Annular Type BOP

Screw and Latch Type

WOM's Type WGK BOP was designed especially for surface installations and is also used on offshore platforms.

The WGK is a universal annular blowout preventer with a long record of proven, quality performance.

Standard operation requires both opening and closing pressure.

Seal-off is affected by hydraulic pressure applied to the closing chamber which raises the piston, forcing the packing unit into a sealing engagement.

Any normal closing unit having a separate pressure regulator valve for the annular BOP and sufficient accumulator volume can be used to operate the WGK.

The WGK is designed to be well pressure assisted in maintaining packing unit seal off once initial seal off has been effected. As well pressure further increases, closure is maintained by well pressure alone.

Pressure Energized Seals are used for dynamically sealing piston chambers to provide safe operation, long seal life, and less maintenance.

Piston Sealing Surfaces Protected by Operating Fluid lowers friction and protects against galling and wear to increase seal life and reduce maintenance.

Operating Chambers are Tested to Full BOP Working Pressure to ensure strength, reliability, and the ability to over-pressurize the chambers in emergencies.

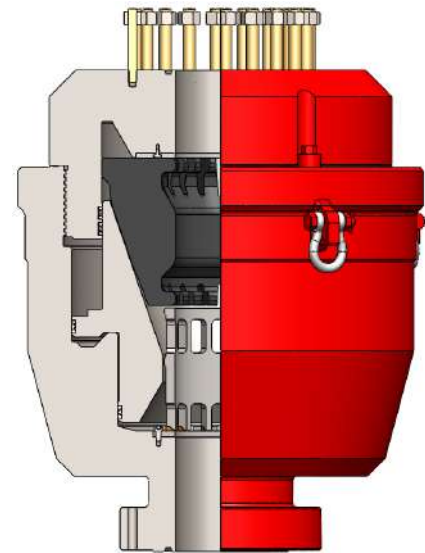

**WOM WGK BOP
(Screw Type)**

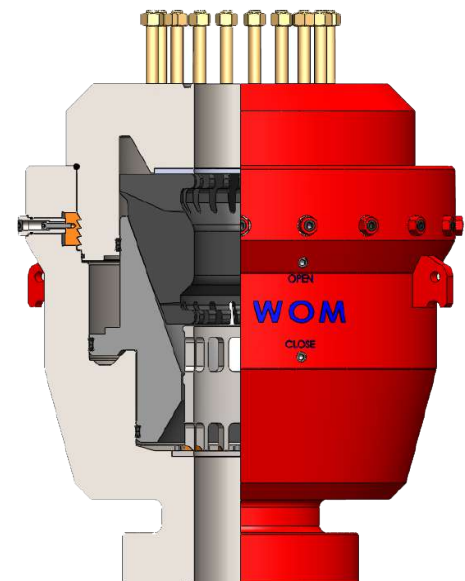

**WOM WGK BOP
(Latch Type)**

WGK Major Components

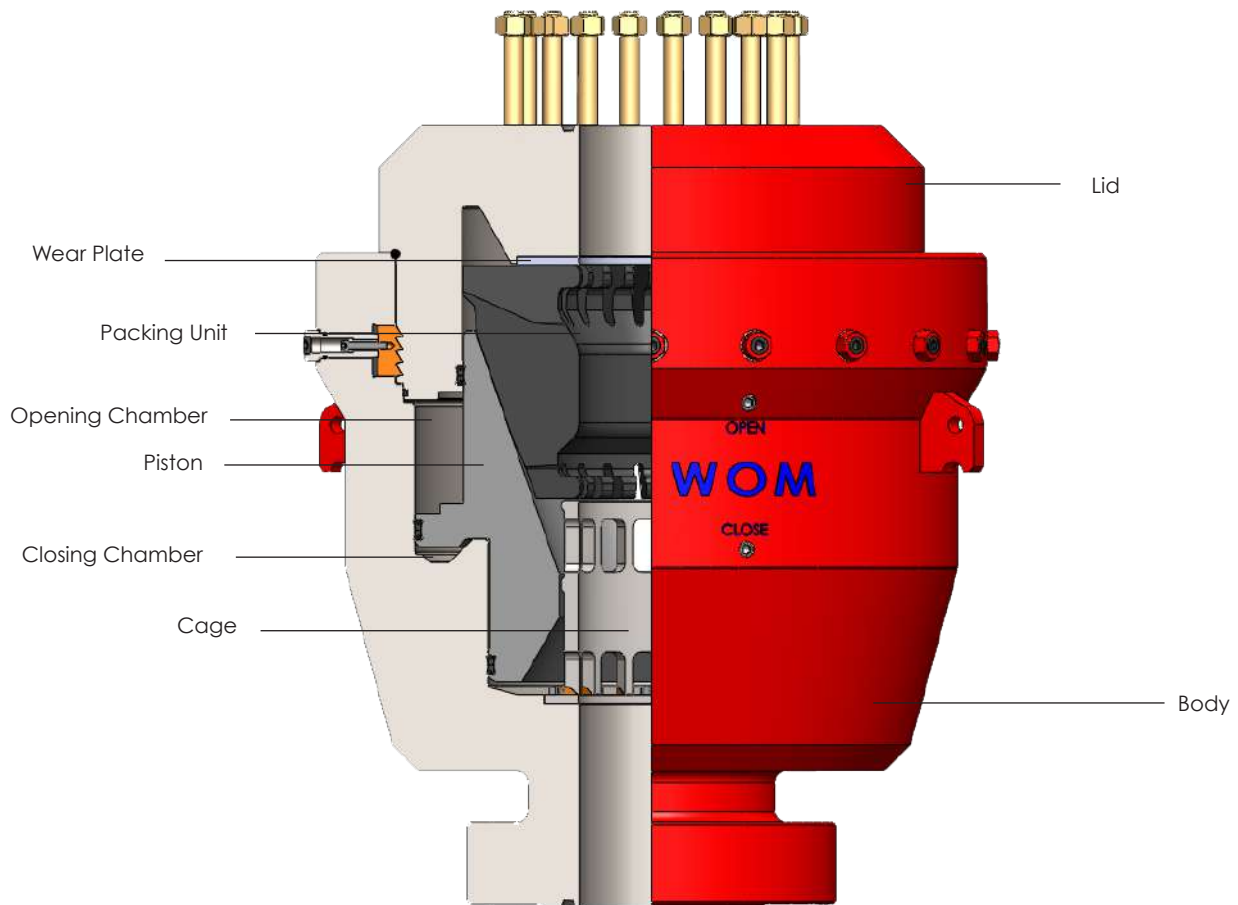

Major Components

WGK Hydraulic Control System

The surface hookup of the WGK connects the hydraulic control lines to the opening and closing chambers of the BOP.

Pressure applied to the closing chamber raises the piston and affects the initial seal between the packing unit and drill pipe. Well pressure or test pressure also acts on the piston below the sealed off packing unit and further increases the closing force acting on the packing unit. As the well pressure or test pressure exceeds the required level the preventer is maintained closed by well pressure alone. As well pressure increases, the closing force on the packing unit also increases. Closing pressure should be proportionally reduced as well pressure is increased in order to maintain optimum closing force on the packing unit and prolong packing unit life.

During normal drilling operations, it is recommended that the pressure regulator valve for the WGK be set at the initial closing pressure for the size pipe being used. This pressure will ensure that initial seal off is achieved should a "kick" be encountered.

During BOP testing operations, once initial seal off is achieved, closing pressure should be proportionally reduced as well pressure is increased.

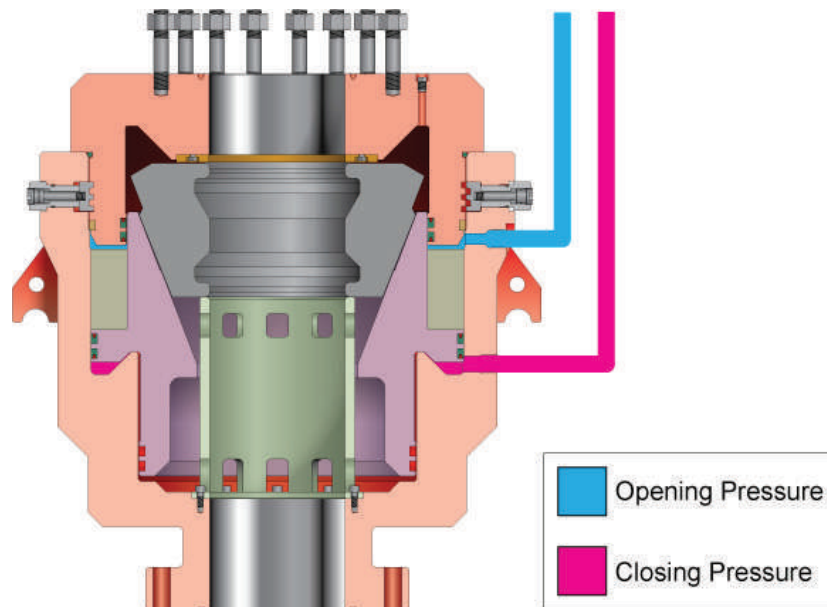

WGK Annular Type BOP

Only Two Moving Parts (piston and packing unit) on the Annular BOP mean few areas are subject to wear. The BOP is safer and more efficient, requiring less maintenance and less downtime.

Long Piston with a length to diameter ratio approaching one eliminates tendencies to cock and bind during operations with off-center pipe or unevenly distributed accumulations of sand, cuttings, or other elements. This design enhances the ability of the packing unit to reopen to full bore position. Conical Bowl Design of the Piston provides a simple and efficient method of closing the packing unit. With the piston serving as a sealing surface against the rubber packing unit, there is no metal-to-metal wear on the sealing surface and thus longer life results.

Field Replaceable Wear Plate in the BOP Lid serves as an upper non-sealing wear surface for the movement of the packing unit, making field repair fast and economical.

Maximum Packing Unit Life is possible with the provision for measuring piston stroke. This measurement indicates remaining packing unit life without disassembly and ensures the longest and safest use of the packing unit.

Three Choices of Packing Unit Rubber Compounds permit more flexible applications.

Screwed Lid Design of the WGK BOP Screw type is a Simple, Efficient, and Strong method of connecting the lid to the body for safe operation with no loose parts being lost down the hole or overboard.

Pressure Energized Seals are used for dynamically sealing piston chambers to provide safe operation, long seal life, and less maintenance.

Piston Sealing Surfaces Protected by Operating Fluid lowers friction and protects against galling and wear to increase seal life and reduce maintenance.

Operating Chambers are Tested to Full BOP Working Pressure to ensure strength, reliability, and the ability to over-pressurize the chambers in emergencies.

NACE MR-01-75 Materials Standards for resistance to sulfide stress cracking are standard.

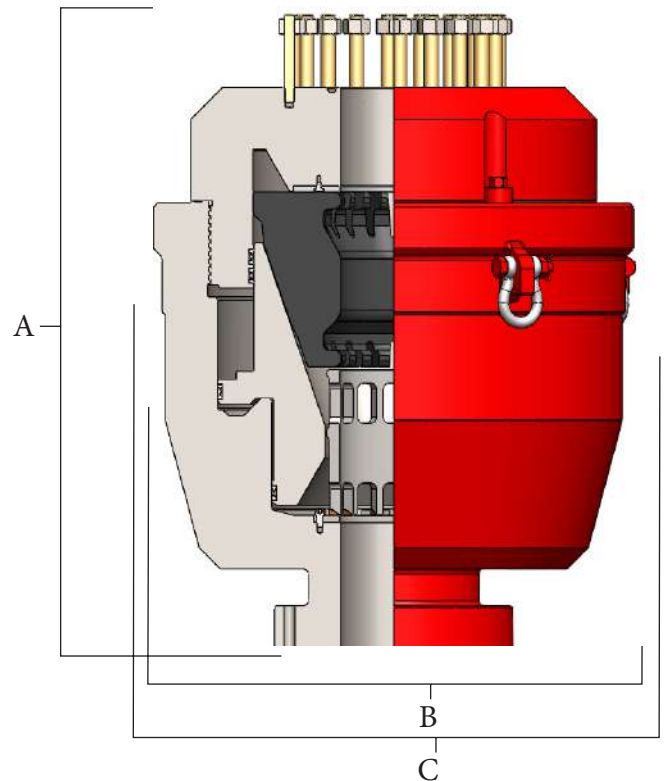

WOM's WGK Annular BOP Screw Type

- A- Height
- B- Body Diameter
- C- Clearance Diameter

See Engineering and Dimensional Data on page 22



WGK Engineering & Dimensional Data (Screw Type)

	7-1/16" - 3M	7-1/16" - 5M	7-1/16" - 10M	7-1/16" - 15M	11" - 3M
Head Type	Screw Type	Screw Type	Screw Type	Screw Type	Screw Type
Operating Chamber Volume (Gal)					
Closing	2.85	2.85	9.42	11.2	7.43
Opening	2.24	2.24	7.08	7.50	5.54
Full Piston Stroke	4-1/8"	4-1/8"	5-1/2"	5-1/2"	6-1/8"
Body Diameter (B)	25.25"	26.00"	43.75"	50.00"	33.75"
Clearance Diameter (C)	29.25"	30.00"	49.50"	61.00"	40.00"
Height (A)					
Flanged Bottom	31.19"	33.62"	48.125"	51.125"	39.75"
Studded Bottom	27.00"	27.50"	–	48.875"	34.375"
Hub Bottom	30.38"	31.62"	47.125"	–	38.125"
Weight (lbs)					
Flanged Bottom	2600	3000	12,200	14,250	5,500
Studded Bottom	2470	2770	–	–	5,140
Hub Bottom	2550	2825	11,900	–	5,350
Standard Ring Groove					
Flanged Bottom	RX45	RX467	BX156	BX156	RX53
Studded Bottom	RX45	RX46	–	BX156	RX53
Hub Bottom	RX45	RX158	BX156	–	RX53

	11" - 5M	11" - 10M	13-5/8" - 3M	13-5/8" - 5M	13-5/8" - 10M
Head Type	Screw Type	Screw Type	Screw Type	Screw Type	Screw Type
Operating Chamber Volume (Gal)					
Closing	9.81	25.10	11.36	17.98	37.18
Opening	7.98	18.97	8.94	14.16	26.50
Full Piston Stroke	7-1/8"	8"	7-1/8"	8-1/2"	10-1/2"
Body Diameter (B)	37.50"	56.50"	40.50"	45.50"	61.00"
Clearance Diameter (C)	44.25"	61.50"	47.50"	52.25"	68.125"
Height (A)					
Flanged Bottom	47.8125"	63.50"	45.25"	51.125"	71.375"
Studded Bottom	39.625"	55.00"	39.375"	46.50"	60.625"
Hub Bottom	44.875"	61.125"	43.00"	51.50"	66.875"
Weight (lbs)					
Flanged Bottom	8200	26,140	8,784	13,800	33,525
Studded Bottom	7750	25,460	8,522	13,100	32,850
Hub Bottom	7920	26,000	8,650	–	32,785
Standard Ring Groove					
Flanged Bottom	RX54	BX158	RX57	BX160	BX159
Studded Bottom	RX54	BX158	RX57	BX160	BX159
Hub Bottom	RX54	BX158	RX57	BX160	BX159



WGK and WGX Engineering Dimensional Data (Latch Type)

	11" 10K	13 5/8" 5K	13 5/8" 10K	21 1/4" 2K
Bore	11 "	13 5/8"	13 5/8"	21 1/4"
Working Pressure	10,000 psi	5,000 psi	10,000 psi	2,000 psi
Shell Test Pressure (Factory Test Only)	15,000 psi	7,500 psi	15,000 psi	3,000 psi
Closing Chamber Test Pressure (Factory Test Only)	2,250 psi	2,250 psi	2,250 psi	2,250 psi
Opening Chamber Test Pressure (Factory Test Only)	2,250 psi	2,250 psi	2,250 psi	2,250 psi
Volume Closing Chamber	25.1 gallons	17.98 gallons	37.18 gallons	31.1 gallons
Volume Opening Chamber	18.9 gallons	14.16 gallons	26.50 gallons	18.9 gallons
Piston Stroke	8"	8 1/2"	10 1/2"	11 1/4"
Port Size	1 NPT	1 NPT	1 NPT	1 NPT
Weight (Varies with end connections)	22,100 lbs	14,800 lbs	35,865 lbs	15,750 lbs

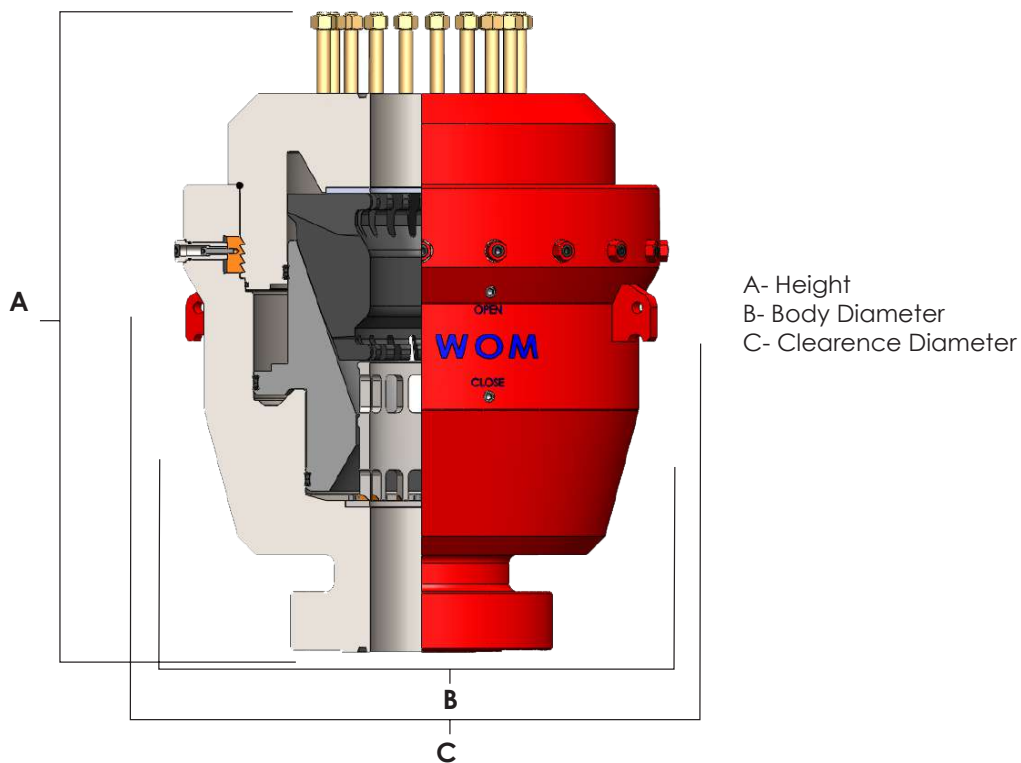

WGK Packing Unit

The heart of the WGK blowout preventer is the packing unit. The unit is manufactured from high quality rubber, reinforced with flanged steel segments. Each unit has a large volume of tough, feedable rubber to meet any requirement.

The molded in steel segments have flanges at the top and bottom. These segments anchor the packing unit within the blowout preventer and control rubber extrusion and flow when sealing off well pressures. Since the rubber is confined and kept under compression, it is resistant to tears, cuts, and abrasion.

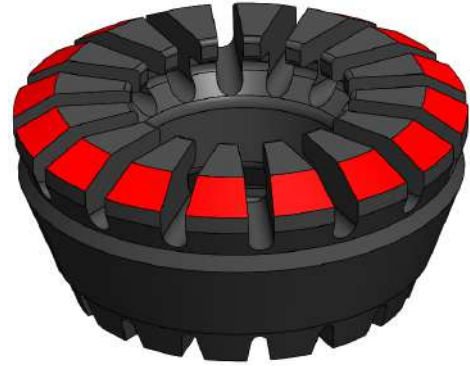

Packing Unit

Packing Unit Selection

All annular blowout preventer packing units are subjected to wear during closure and stripping. The design of the WGK blowout preventer causes closure wear to occur on the outside of the packing unit while stripping wear occurs on the inside. Thus, the stripping life of the packing unit is little affected by wear from routine closures.

Natural Rubber is compounded for drilling with water-base drilling fluids. Natural rubber can be used at operating temperatures between -30° F to 225° F.

Nitrile Rubber (a synthetic compound) is for use with oil-base or oil-additive drilling fluids. It provides the best service with oil-base muds, when operated at temperatures between 20° F to 190° F.

Neoprene Rubber is for low-temperature operating service and oil-base drilling fluids. It can be used at operating temperatures between -30° F to +170° F. Neoprene rubber provides better service with oil-base drilling fluids than Natural rubber. It has better cold temperature elasticity than Nitrile rubber; but it is detrimentally affected by extended high temperature applications.

Seals are manufactured from a special Nitrile rubber material which provides long, trouble free service in sealing against oil, gas, or water.

Expected H₂S Service does not affect selection of packing unit material. H₂S Service will reduce the service life of rubber products, but the best overall service life is obtained by matching the packing unit material with the requirements of the specific drilling fluid. Performance of elastomeric materials can vary significantly, depending on the nature and extent of exposure to hydrogen sulfide. The operator should monitor pressure sealing integrity frequently to assure no performance degradation has occurred.

Storage conditions such as light, heat, or adverse conditions, are significant factors in the storage life of packing units.

WGK BOP Care & Maintenance (Screw & Latch Type)

Prior to placing the GK blowout preventer into service, the following visual inspections should be performed:

1. Inspect upper and lower connections for pitting, wear, and damage especially in ring grooves and stud bolt holes. Worn or damaged ring grooves must be welded, machined, and stress relieved. Worn or damaged stud bolt holes can be drilled and tapped to the next larger size and fitted with step-studs.
2. Check the body for wear and damage, especially in the internal cylinder walls for pits and vertical scores. Minor pits and scores can be removed in the field with emery cloth. Repaired surface should be coated with silicon grease or castor oil. Severe pits and scores may require machining and/or welding which should be performed in a WOM approved machine shop. Cracks must be corrected.
3. Inspect the vertical bore for wear and damage from drill string and drill tools, especially in the area of thering grooves. If wear is excessive, the area must be repaired.
4. Check for piston damage and wear, especially the inner and outer walls for pits and vertical scores and the tapered bowl for pits and gouges. Minor pits and scores on the walls can be removed in the field with emery cloth. Repaired surface should be coated with silicon grease or castor oil. Severe pits and scores may require machining and/or welding which should be performed by a WOM approved machine shop.
Pits and gouges in the tapered bowl should be filled with a permanent type adhesive, such as epoxy. Sharp or rolled edges should be removed with emery cloth or a grinder. Repair will be satisfactory when a relatively smooth surface is achieved.
5. Check the wear plate in the inner bottom face of the lid for any abrasion. In addition to the aging process of time and use, wear of this metal surface is produced by the combination of vertical (upward thrust) and lateral forces. These forces are generated each time the packing unit is closed. Severe wear is exhibited in the form of grooves or channels shaped by the steel segments of the packing unit. The inner bottom face of the lid serves as a wall to prevent upward movement of the packing unit. Friction between these metal surfaces is controlled at a level which does not impair lateral movement of the packing unit. Repair of this surface is accomplished by replacing the wear plate.
6. Inspect the packing unit for wear, cracking, hardness, and correct elastomer composition.
7. Check seal ring for nicks, cuts, fraying of lips, and abrasion. Worn or damaged seal rings should be replaced.



29 1/2" 500 PSI MSP Diverter (Latch Type)

The MSP Diverter was developed as a compact, lightweight unit for medium pressure drilling service, remedial work and well servicing. It can be used on surface and subsea installations. Standard operation requires both opening and closing pressure. Seal off is affected by hydraulic pressure applied to the closing chamber which raises the piston, forcing the packing unit into a sealing engagement. Any normal closing unit having a separate regulator valve for the annular BOP and sufficient accumulator volume can be used to operate the MSP.

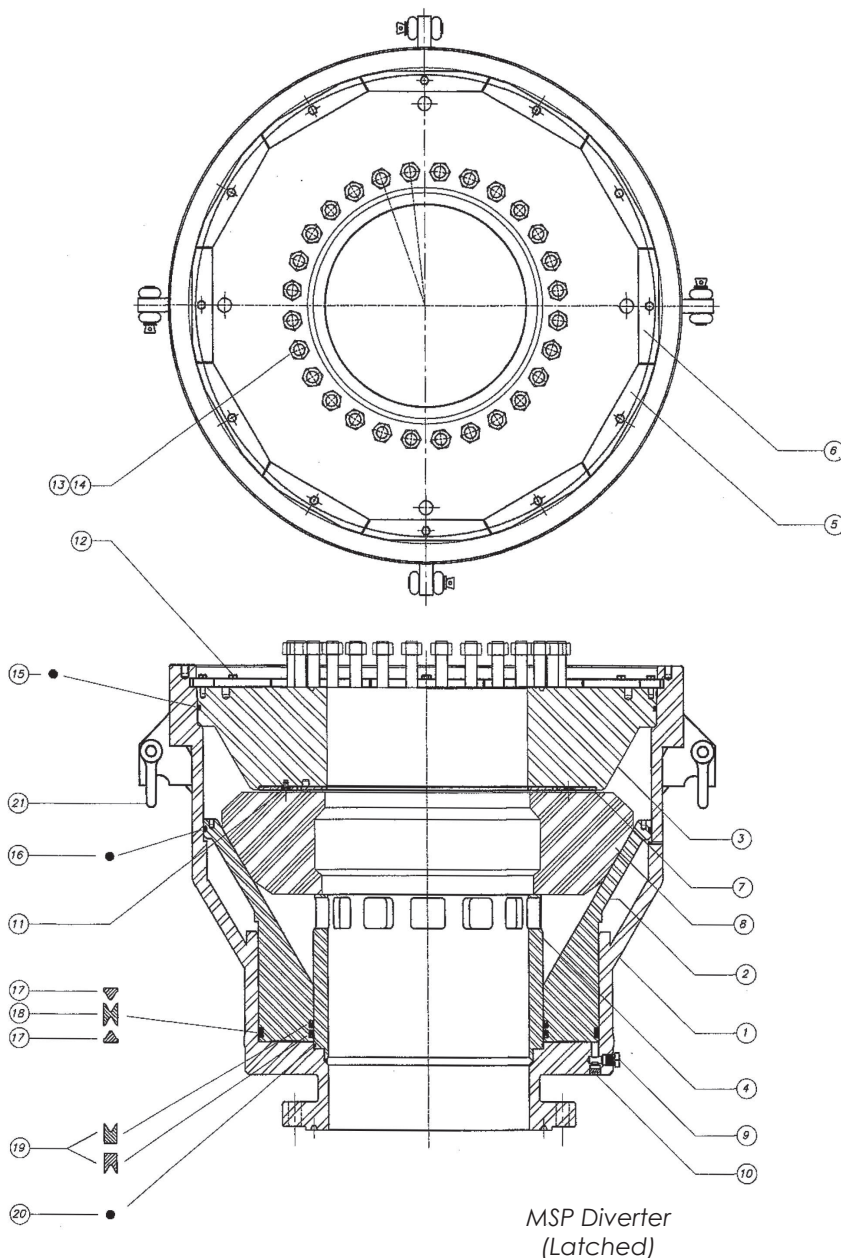

29 1/2" 500 PSI MSP Diverter Parts

Item	Description
1	Body
2	Lid
3	Piston
4	Cage
5	Locking Plate, Long
6	Locking Plate, Short
7	Wear Plate
8	Packing Element
9	Pipe Plug, Hex HD
10	Pipe Plug, Socket HD.
11	Hex Hd. Cap Screw
12	Hex Hd. Cap Screw
13	Stud
14	Nut
15	O-ring: Lid
16	O-ring: Upper, Piston
17	Non-extrusion ring: Outer, Piston
18	U-seal: Double, Outer, Piston
19	U-seal: Inner, Piston
20	O-ring: Cage
21	Anchor Shackle



WORLDWIDE OILFIELD MACHINE



VALVES & CONTROLS
A WOM group company



Magnum Technology Center
A WOM Group Company

We are Worldwide Oilfield Machine (WOM) - a global company pioneering Flow Control Solutions for the Surface & Subsea sectors of the oil & gas industry. Headquartered in Houston, Texas, we have manufacturing facilities, engineering centers, sales offices and assembly/testing workshops all over the world.

Our strength is our robust infrastructure that allows us complete control over quality, costs and delivery. With more than 20 patents and noted accreditations, our very own R&D facilities and 24x7 service centers across the globe we have the required capabilities & resources to deliver all your manufacturing needs for the industry.

www.womgroup.com



facebook.com/womglobalgroup
instagram.com/womglobalgroup
twitter.com/womglobalgroup
linkedin.com/company/worldwideoilfieldmachine